

**DIAPHRAGM VALVE, SERIES - 'S2K'  
RUBBER LINED (SEALED BONNET)**

DATE : 15 APR 2008

DRG.NO : DS0003

07  
REV.NO.

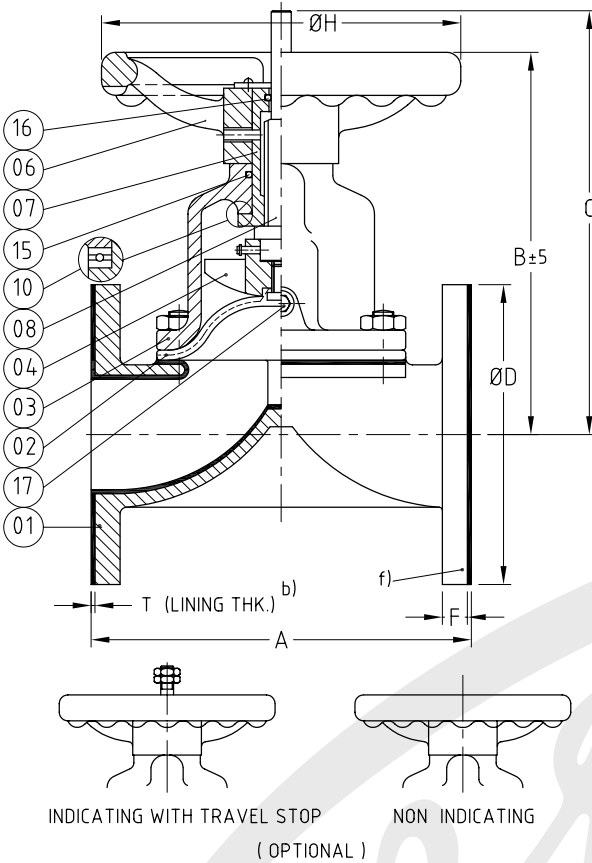

PT.NO.	PART NAME	MATERIAL
01	BODY	CI/ DI / WCB
02	DIAPHRAGM a)	
03	BONNET	CI
04	COMPRESSOR	CI
06	HANDWHEEL	CI
07	STEM BUSHING	S.G.IRON
08	STEM	410
10	THRUST BEARING c)	STEEL
15	'O' RING SEAL (BUSHING)	BUNA - N
16	'O' RING SEAL (STEM) d)	BUNA - N
17	'V' NOTCH VENT PLUG	STEEL

- a) DIAPHRAGM HARDNESS : \_\_\_\_\_ SHORE 'A'.
- b) LINING HARDNESS : \_\_\_\_\_ SHORE 'A'
- c) FOR SIZES 80 AND HIGHER.
- d) NOT APPLICABLE FOR NON INDICATING TYPE.
- f) FLANGE DRILLING :

**NOTE :**

- 1) ONLY DIMENSION 'A' CONFORMS TO EN 558- 1. (SIZE 350 - SERIES 7, BDK STANDARD). OTHER DIMENSIONS ARE ONLY INDICATIVE. WEIGHT(Wt) INDICATED IS APPROXIMATE.

DESIGN STD : EN 13397 / BS 5156  
TESTING STD : EN 12266 - 1 / BS 6755 - 1  
ALL DIMENSIONS ARE IN mm.

SIZE	15	20	25	32	40	50	65	80	100	125	150	200	250	300	350	
A	SERIES 7	114	123	133	152	165	196	222	260	313	364	414	529	645	759	759
	SERIES 1	130	150	160	180	200	230	290	310	350	400	480	600	730	850	980
B	92	100	114	115	153	160	180	233	256	306	368	479	585	689	830	
C	90	102	118	121	164	179	206	260	296	362	431	584	699	825	1025	
T	3			4			5									
ØD	95	105	115	140	150	165	185	200	230	254	285	343	406	485*	533	
ØH	70		100		140		180	225		310	368	471	587	690		
F	CI	12.0	12.0	12.0	12.0	15.0	17.5	18.0	19.0	23.8	23.8	25.4	22.0	24.0	24.0	26.0
	STEEL	9.7	10.5	11.2	13.0	14.2	15.8	17.5	19.0	20.0	22.0	22.0	20.0	22.0	22.0	22.0
Wt. kg	SERIES 7	2.5	2.6	3.5	4.5	7	10	15	22	37	62	91	163	240	418	480
	SERIES 1	2.8	3.2	4.2	5.5	8	15	19	26	42	68	106	185	275	480	550
OPT.PR. bar	16.00						10.50			10.00		7.00	6.00			
QTY																

\*460 FOR SERIES 1

TEST PRESSURE , bar																	
HYD	SHELL	24.00						15.75			15.00		10.50	9.00			
	SEAT	17.60						11.50			11.00		7.70	6.60			
AIR SEAT		5.00															
TAG NO																	
CODE	CI	DI	WCB	S.G.IRON	410												
MATERIAL	IS: 210	A395	A 216	IS: 1865	A 276												
SPECN	FG 260	60-40-18	WCB	500/7	410												

CUSTOMER : \_\_\_\_\_  
ORDER NO. : \_\_\_\_\_  
JOB/PROJECT : \_\_\_\_\_

**MANUFACTURED BY : M/s B.D.K. ENGINEERING INDUSTRIES LIMITED, HUBLI - 580 030 , INDIA**

APPROVED : \_\_\_\_\_  
CHECKED : \_\_\_\_\_  
DRAWN : \_\_\_\_\_

FOR APPROVAL  FOR RECORD