

SEAL WELDED BONNET DESIGN

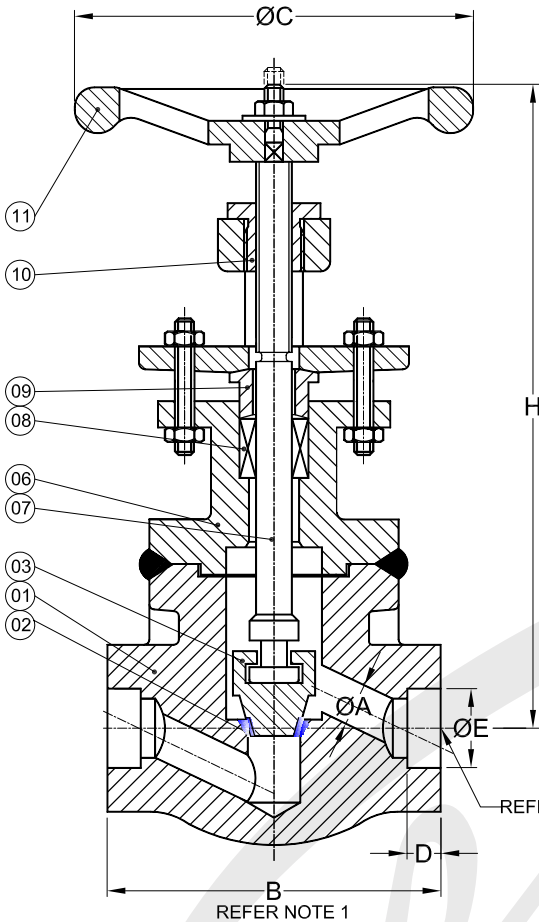

PT.NO.	PART NAME	MATERIAL
01	BODY	A 105 / F 304 / F 316 / F 11 / F 22
02	SEAT RING - STELLITED	INTEGRAL
03	PLUG - STELLITED	CA 15 / CF 8 / CF 8M
06	BONNET	A 105 / F 304 / F 316 / F 11 / F 22
07	STEM	410 / 304 / 316
08	PACKING	BRAIDED MOULDED GRAPHITE
09	GLAND	410 / 304 / 316
10	YOKE SLEEVE	NI-RESIST ASTM A-439 GR-D2
11	HANDWHEEL	MALLEABLE IRON IS:2108 Gr. B

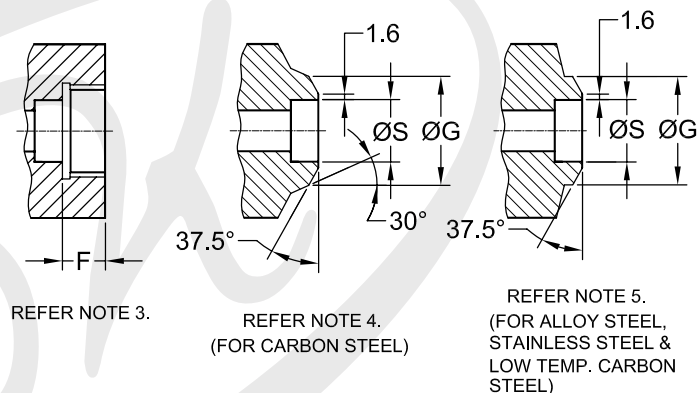

DESIGN STD.: API 602-2005/ISO 15761-2002
 TESTING STD.: API 598 / BS EN 12266-1:2003.
 ALL DIMENSIONS ARE IN MM.

CLASS		1500					
SIZE		15	20	25	32	40	50
ØA		8.0	9.0	14	20	25	27
B ±5		88	92	106	128	128	140
ØC ±5		110	110	170	170	170	200
D ±0.3		10	13	13	13	13	16
ØE ^{+0.5} / _{-0.0}		21.8	27.2	33.9	42.7	48.8	61.2
F		13.5	14.5	17.3	20	21	22
ØG		23	28	35	44	50	62
H APPROX.	OPEN	178	190	222	250	250	296
	CLOSE	164	173	204	222	222	256
ØS	SCH 40	15.8	20.9	26.7	35.1	40.9	52.5
	SCH 80	13.9	18.9	24.3	32.5	38.1	49.3
	SCH 160	11.8	15.6	20.7	29.5	34	42.9
Approx. Wt.-kg.		2.45	3.45	4.2	10.3	13.5	14.25
QTY.							
TAG. No.							

- NOTE :
- DIMN. 'B' AS PER MANUFACTURER'S STANDARD.
 - SOCKET WELD ENDS-API 602-2005/ASME-B16.11
 - SCREWED ENDS TO BSP / BSPT - BS 21 / IS 554. NPT - ASME-B1.20.1.
 - BUTT WELD ENDS TO ASME-B16.25, FIG 2 TYPE 'A'
 - BUTT WELD ENDS TO ASME-B16.25, FIG 4
 - TEST PRESSURES FOR IBR, VALVES SHALL BE AS PER IBR, REQUIREMENTS.

CODE	A 105	F 304	F 316	CA 15	CF 8	CF 8M	410	304	316	F 22
MATL SPECN	A 105	A 182 F 304	A 182 F 316	A 217 CA 15	A 351 CF 8	A 351 CF 8M	A 276 410	A 276 304	A 276 316	A 182 F 22

TEST PRESSURE , bar		
HYD	SHELL	389
	SEAT	285
	BACK SEAT	285
AIR	SEAT	7

CUSTOMER: _____
 ORDER NO.: _____
 JOB/PROJECT: _____

APPR: _____
 CHD: _____
 DRN: _____
 FOR APPROVAL FOR RECORD