

SCREWED & SEAL WELDED BONNET

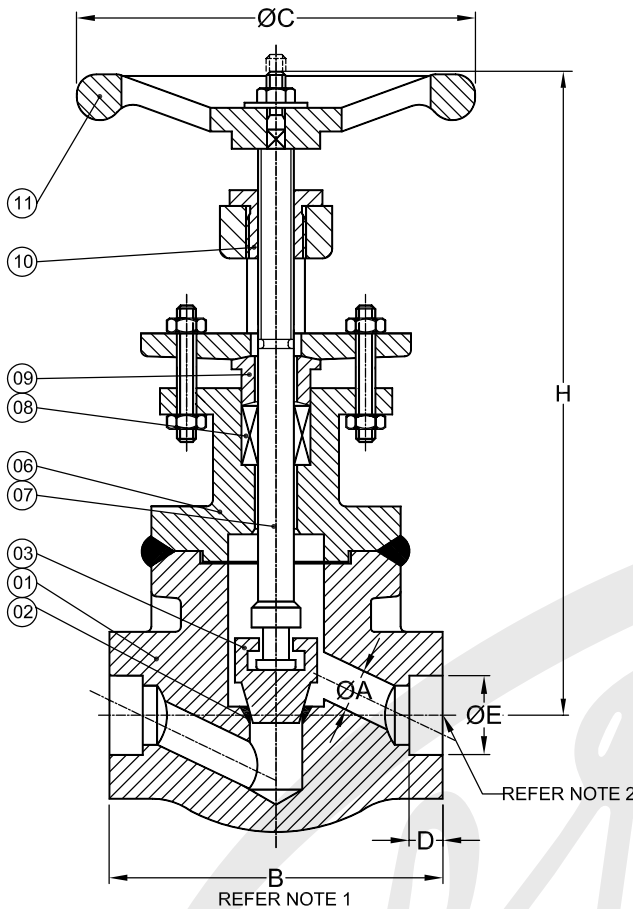

PT.NO.	PART NAME	MATERIAL
01	BODY	A 105 / F 304 / F 316
02	SEAT RING - STELLITED	INTEGRAL
03	PLUG - STELLITED	CA 15 / CF 8 / CF 8M
06	BONNET	A 105 / F 304 / F 316
07	STEM	410 / 304 / 316
08	PACKING	BRAIDED GRAPHITE RINGS
09	GLAND	410 / 304 / 316
10	YOKE SLEEVE	NI-RESIST ASTM A-439 GR.D2
11	HANDWHEEL	MALLEABLE IRON IS:2108 Gr. B

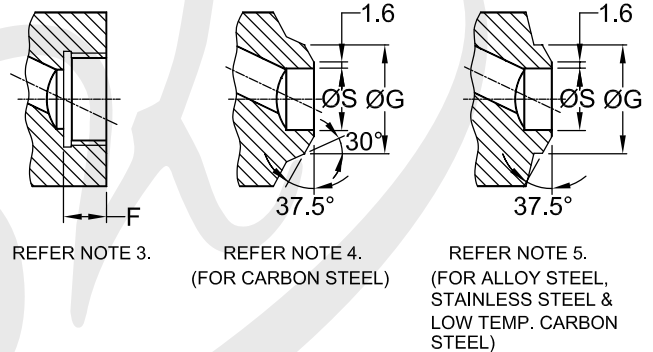

DESIGN STD.: ASME B16.34(ANSI).
TESTING STD.: API 598 / BS EN 12266-1:2003.
ALL DIMENSIONS ARE IN MM.

CLASS		2500		
SIZE		15	20	25
ØA		11	14	19
B ±5		106	128	140
ØC ±5		170	200	200
D ±0.3		9.7	12.7	12.7
ØE		21.8	27.2	33.9
F		13.5	14.5	17.3
ØG		23	28	35
H APPROX.	OPEN	217	242	281
	CLOSE	204	223	256
ØS	SCH 40	15.8	20.9	26.7
	SCH 80	13.9	18.9	24.3
Approx. Wt.-kg.		4.2	10.3	14.25
QTY.				
TAG. No.				

NOTE :

- DIMN. 'B' AS PER MANUFACTURER'S STANDARD.
- SOCKET WELD ENDS TO ASME - B16.11.
- SCREWED ENDS TO BSP / BSPT - BS 21 / IS 554. NPT - ANSI-B1.20.1.
- BUTT WELD ENDS TO ANSI-B16.25, FIG 2 TYPE 'A'
- BUTT WELD ENDS TO ANSI-B16.25, FIG 4
- TEST PRESSURES FOR IBR, VALVES SHALL BE AS PER IBR, REQUIREMENTS.

CODE	A 105	F 304	F 316	CA 15	CF 8	CF 8M	410	304	316	F 22
MATL SPECN	A 105	A 182	A 182	A 217	A 351	A 351	A 276	A 276	A 276	A 182
		F 304	F 316	CA 15	CF 8	CF 8M	410	304	316	F 22

CUSTOMER: _____
ORDER NO.: _____
JOB/PROJECT: _____

TEST PRESSURE , bar		
HYD	SHELL	647
	SEAT	475
	BACK SEAT	475
AIR	SEAT	7

APPROVED :

CHECKED :

DRAWN :

FOR RECORD

FOR APPROVAL