

('K' DESIGN TYPE)

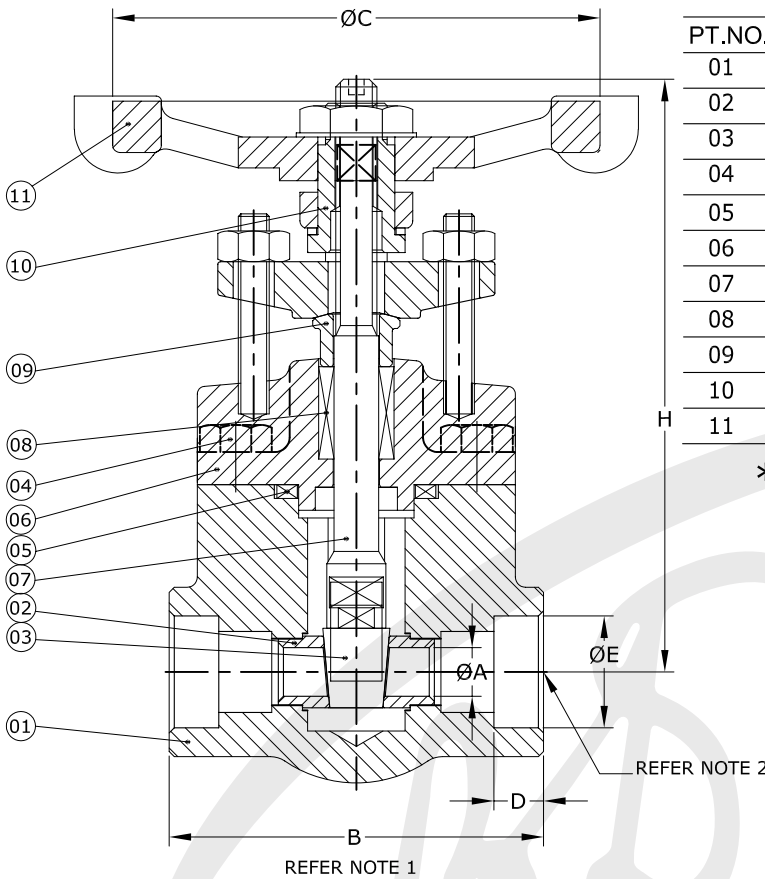

PT.NO.	PART NAME	MATERIAL
01	BODY	A 105 / F 304 / F 316
02	SEAT RING	410 / 304 / 316
03	WEDGE	CA 15 / CF 8 / CF 8M
04	HEX.BOLT	A193 Gr. B7
05	GASKET	SPIRAL WOUND SS:304 ASB. FILLED
06	BONNET	A 105 / F 304 / F 316
07	STEM	410 / 304 / 316
08	PACKING	*
09	GLAND	410 / 304 / 316
10	YOKE SLEEVE	S. G. IRON IS:1865 / 74, SG 500 / 7
11	HANDWHEEL	MALLEABLE IRON IS:2108 Gr. B

* TOP&BOTTOM 1NO.GRAPHITED ASB.INCONEL WIRE RNFD. IN BETWEEN MOULDED GRAPHITE RINGS

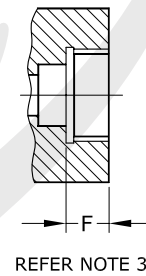

DESIGN STD.: API 602 / BS 5352..
TESTING STD.: API 598 / BS EN 12266-1:2003
ALL DIMENSIONS ARE IN MM.

CLASS	800				
SIZE	15	20	25	40	50
ØA	9.5	12.7	18	30	36
B ±5	73	82	90	127	148
ØC	95	95	103	127	147
D±0.3	9.7	12.7	12.7	12.7	15.8
ØE	21.8	27.2	33.9	48.8	61.2
F	13.5	14.5	17.3	21	22
H APPROX.	116	132	150	194	234
Approx. Wt.-kg.					
QTY.					
TAG. No.					

NOTE:

- DIMN. 'B' AS PER MANUFACTURER'S STANDERD.
- SOCKET WELD ENDS TO ASME - B16.11.
- SCREWED ENDS TO BSP/BSPT-BS 21/IS 554. NPT-ANSI-B1.20.1.
- TEST PRESSURES FOR IBR, VALVES SHALL BE AS PER IBR, REQUIREMENTS.

CODE	A 105	F 304	F 316	CA 15	CF 8	CF 8M	410	304	316	F 22
MATL	A 105	A 182	A 182	A 217	A 351	A 351	A 276	A 276	A 276	A 182
SPECN	A 105	F 304	F 316	CA 15	CF 8	CF 8M	410	304	316	F 22

TEST PRESSURE , bar

HYD	SHELL	207
	SEAT	152
	BACK SEAT	152
AIR	SEAT	7

CUSTOMER: _____
ORDER NO.: _____
JOB/PROJECT: _____

APPR:

CHD:

DRN:

FOR RECORD

FOR APPROVAL