

**BUTT WELD ENDS (SHORT PATTERN)**

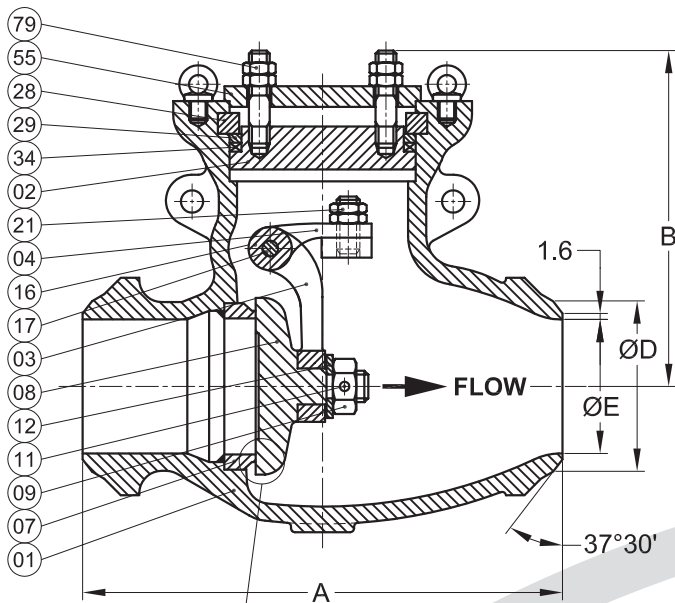

PT.NO.	PART NAME	MATERIAL					
		WCB	WC6	WC9	CF8	CF8M	
01	BODY	WCB	WC6	WC9	CF8	CF8M	
02	COVER	WCB	WC6	WC9	CF8	CF8M	
03	HINGE	WCB	WC6	WC9	CF8	CF8M	
04	BRACKET	WCB	WC6	WC9	CF8	CF8M	
07	SEAT RING *	WCB	WC6	WC9	CF8	CF8M	
08	DISC *	WCB	WC6	WC9	CF8	CF8M	
09	DISC NUT	410	410	410	304	316	
11	SPLIT PIN -DISC NUT	410	410	410	304	316	
12	WASHER - DISC	410	410	410	304	316	
16	SPACER WASHER	410	410	410	304	316	
17	HINGE PIN	410	410	410	304	316	
21	STUD / LOCK NUT	410	410	410	304	316	
28	SEGMENT RING	CA15	CA15	CA15	CF8	CF8M	
29	SUPPORT RING	CA15	CA15	CA15	CF8	CF8M	
34	PRESSURE SEAL RING	EXPANDED GRAPHITE					
55	COVER RETAINER	WCB	WC6	WC9	WCB	WCB	
79	STUD /NUT /LK NUT COVER TO COVER RET	B7/2H	B16/7			B7/2H	

**NOTES :**

- 1) DIMN. 'A' CERTIFIED AND CONFORMS TO ASME B 16.10.
- 2) BUTT WELD ENDS TO ASME B16.25, SCH-80/120/160.
- 3) \* SEATRING & DISC ARE STELLITE - FACED.
- 4) FOR SIZES 50, 80 & 100 THE SEAT FACE IS TAPERED.
- 5) ALTERNATE TO EYE BOLT, BODY MAY HAVE LIFTING LUG.
- 6) ALL DIMENSIONS ARE IN mm.

APPLICABLE FOR SIZES  
50, 80 & 100, (See note -4)

DESIGN STD : ASME B16.34 / TESTING STD : API 598

CLASS	900								1500								
	80	100	125	150	200	250	300	50	65	80	100	125	150	200	250	300	
<b>SIZE</b>	305	356	432	508	660	787	914	216	254	305	406	483	559	711	863	990	
<b>A</b>	305	356	432	508	660	787	914	216	254	305	406	483	559	711	863	990	
<b>B (APPROX)</b>	235	265	310	325	440	535	630	180	195	235	265	310	325	460	535	630	
<b>ØD</b>	91	117	144	172	223	278	329	62	75	91	117	144	172	223	278	329	
<b>ØE</b>	SCH-160	66.5	87.5	109.5	132	173	216	257	43	54	66.5	87.5	109.5	132	173	216	257
	SCH-120	—	92	116	140	182.5	230	273	—	—	—	92	116	140	182.5	230	273
	SCH-80	73.5	97	122	146.5	193.5	243	289	49.3	59	73.5	97	122	146.5	193.5	243	289
<b>Approx. Wt.- kg.</b>	31	41	69	96	215	330	546	31	34	37	64	96	145	353	602	691	
<b>QTY.</b>																	
<b>TAG. No.</b>																	

CODE	WCB	WC6	WC9	CA15	CF8	CF8M	410	304	316	B7/B16	2H/7
<b>MATERIAL</b>	A216	A217	A217	A217	A351	A351	A276	A276	A276	A193	A194
<b>SPECIFICATION</b>	WCB	WC6	WC9	CA15	CF8	CF8M	410	304	316	B7/B16	2H/7

TEST PRESSURE , bar			
CLASS	900	1500	
HYD.	SHELL	230	384
	SEAT	169	282
	MIN.SEAT	43	71

CUSTOMER \_\_\_\_\_  
ORDER NO. \_\_\_\_\_  
JOB/PROJECT \_\_\_\_\_

**MANUFACTURED BY : B.D.K. ENGINEERING INDUSTRIES LIMITED, HUBLI - 580 030**

APPROVED : \_\_\_\_\_  
CHECKED : \_\_\_\_\_  
DRAWN : \_\_\_\_\_

FOR APPROVAL  FOR RECORD